

# The function of the ACE2/Ang(1-7)/Mas receptor axis of the renin-angiotensin system in myocardial ischemia reperfusion injury

J.-X. XIE<sup>1</sup>, J. HU<sup>2</sup>, J. CHENG<sup>1</sup>, C. LIU<sup>1</sup>, X. WEI<sup>1</sup>

<sup>1</sup>Institute of Cardiovascular Disease, Key Laboratory for Arteriosclerosis of Hunan Province, Hunan International Scientific and Technological Cooperation Base of Arteriosclerotic Disease, Hengyang Medical College, University of South China, Hengyang, Hunan, PR China

<sup>2</sup>Department of Pathology, The First Affiliated Hospital of University of South China, Hengyang, Hunan, PR China

*Jiixin Xie and Jia Hu contributed equally to this work*

**Abstract.** – **OBJECTIVE:** Angiotensin-converting enzyme 2(ACE2) is a critical element of the renin-angiotensin system (RAS), which can convert angiotensin (Ang)II to Ang(1-7), followed by binding Mas receptor (MasR) and subsequently produces cardioprotective effects through various signal transduction pathways. It has been discovered in research that activation of the RAS contributes a crucial influence during the myocardial ischemia reperfusion injury (MIRI) development. The features of ACE2, Ang(1-7), and MasR, as well as the function of the ACE2/Ang(1-7)/MasR axis in MIRI, are discussed in our review, with the therapeutic potential of this axis as a new treatment option for MIRI patients shown.

**MATERIALS AND METHODS:** To retrieve a thorough collection of studies, we performed a search in PubMed using the following combination of keywords: (ACE2) or (Ang1-7) or (Mas receptor) and (Myocardial Ischemia reperfusion injury). The time limits used for the search were 1986 to 2021.

**RESULTS:** In total, 367 articles were included. Titles and abstracts of articles were screened for relevance, and all relevant articles published in English were included.

**CONCLUSIONS:** ACE2, a prominent member of the RAS, performs a crucial regulatory function in the cardiovascular system. ACE2 regulates the RAS inversely mainly by hydrolyzing the harmful AngII to the beneficial Ang(1-7). Increasing or activating ACE2 or Ang(1-7) may help prevent and treat MIRI. However, additional research into the specific processes behind the ACE2/Ang(1-7)/MasR axis in MIRI is necessary, as is the performance of additional in-depth studies to go from basic research to clinical translation.

## Key Words:

Angiotensin-converting enzyme 2, Angiotensin(1-7), Ischemia reperfusion injury, Mas receptor, Myocardial ischemia reperfusion injury.

## Introduction

Despite the gradual improvement in medical care that has occurred as a result of technological advancements and social development, ischemic heart disease continues to be a global pandemic, with significant rates of morbidity and death worldwide, resulting in significant health and psychological burden on people<sup>1</sup>. Reperfusion therapy includes percutaneous coronary intervention (PCI), the use of thrombolytic drugs, or coronary artery bypass grafting to recanalize the occluded arteries, which is the most successful treatment for myocardial ischemia at present<sup>2</sup>. Although reperfusion therapy is the most effective treatment, reperfusion therapy can also lead to further tissue damage called myocardial ischemia reperfusion injury (MIRI)<sup>3</sup>. MIRI has a complicated and multifactorial process that includes, but is not limited to, (1) oxygen radical destruction; (2) calcium overload; and (3) aseptic inflammatory reactions<sup>4</sup>. In the past few years, the involvement of the RAS in MIRI has been a popular focus of research. It has already been proven that cardiac ischemia reperfusion increases angiotensin(Ang) II levels in the local myocardium and circulatory system<sup>5</sup>. The increase in AngII has many cardiac damaging effects, such as promoting vasoconstriction and vasospasm,

reducing coronary flow reserve, generating oxidative stress damage by raising reactive oxygen species (ROS), stimulating the production of specific cytokines/chemokines to engage neutrophils in the inflammatory response, etc<sup>6</sup>.

The RAS is thought to include a huge number of different enzymes and effector peptides, all of which are important in normal physiology and cardiovascular disease pathogenesis<sup>7</sup>. In classical RAS, first, angiotensinogen is degraded by renin, which results in the synthesis of AngI, and subsequently, angiotensin-converting enzyme (ACE) can hydrolyze AngI to form AngII, which in turn binds to the angiotensin I type 1 and type 2 receptor (AT1R and AT2R). AngII stimulates the AT1R, leading to increased vasoconstriction, inflammation, oxidative stress, and water-salt re-absorption. Conversely, ACE2 has the ability to degrade AngII to generate Ang(1-7), since it has a cardioprotective effect *via* activating the Mas receptor(MasR)<sup>8</sup>. This demonstrates the presence of two RAS counter-regulatory arms that are mutually exclusive: the ACE/AngII/AT1R axis and the ACE2/Ang(1-7)/MasR axis<sup>9</sup>.

With a firmer grasp on the ACE2/Ang(1-7)/MasR axis, it may be feasible to identify this axis as a viable therapeutic target for MIRI therapy in the near future. In this review we will address the properties of ACE2, Ang(1-7), and MasR, as well as the function of the ACE2/Ang(1-7)/MasR axis in MIRI. Additionally, we will illustrate the potential of the ACE2/Ang(1-7)/MasR axis as a new MIRI therapeutic target.

## Overview of the ACE2/Ang(1-7)/MasR Axis

### ACE2

Catalytic region amino acid sequences of ACE2 and ACE show 42 percent homology<sup>10</sup>. There is 48% homology between cytoplasmic and transmembrane structural regions of ACE2 and collectrin, a transporter protein<sup>11</sup>. It is evident that *ACE2* was meant to be the outcome of an early evolutionary union from the ACE, as well as collectrin genes. Contrary to popular belief, even though it is structurally similar to ACE and has many of the same biochemical features, the classical ACE inhibitors (ACEI) have no effect on ACE2<sup>12</sup>. Further research has demonstrated that ACE2 and ACE have fundamentally different enzymatic function, with ACE working as a peptidyl dipeptidase to cut a dipeptide by the

C-terminus of the sensitive substrate. While the carboxypeptidase ACE2 slashes a single amino acid by the protein's C-terminus<sup>10,13</sup>. This would suggest that ACE2 does not convert AngI into AngII, but rather AngI into Ang(1-9)<sup>14</sup>.

ACE2 is found in a number of tissues, with the most abundant levels of expression seen in the heart, alveolar epithelial cells, kidney, gastrointestinal tract, and testis<sup>15</sup>. A study<sup>16</sup> using mononuclear RNA sequencing in the human heart discovered that the expression of ACE2 was seen in a variety of cells, such as cardiomyocytes, fibroblasts, smooth muscle cells, endothelial cells, and pericytes. In the RAS, ACE2 regulates AngI and AngII levels by converting AngI into Ang(1-9) and AngII into Ang(1-7), which subsequently binds to MasR and forms the RAS's "protective arm", resulting in vasodilatory, anti-inflammatory, anti-proliferative, anti-oxidative stress and anti-fibrotic effects. This mitigates the AngII/AT1R arm's adverse effects (Figure 1)<sup>17</sup>. ACE2 has been gradually discovered over the last two decades as a multifunctional protein that, in addition to catalyzing the generation of Ang(1-7) peptides, also has a variety of non-catalytic functions, including coronavirus receptors and the control of intestinal amino acid transport<sup>18</sup>. Furthermore, ACE2 has been implicated in the pathogenesis of severe acute respiratory syndrome (SARS) and coronavirus disease (COVID-19)<sup>19</sup>.

### Ang(1-7)

There are several enzymes and processes that may result in the formation of Ang(1-7). First and foremost, the most effective and well-known enzyme for the creation of Ang(1-7) is ACE2, which may create Ang(1-7) either directly from the dissolution of AngII or indirectly through AngI *via* the Ang(1-9) intermediate, depending on the circumstances<sup>20</sup>. And again, since ACE2 has 400 times more affinity for AngII than AngI, the former is more beneficial<sup>21</sup>. ACE2 can convert AngI to Ang(1-9), after that, Ang(1-9) is degraded by ACE, prolyl oligopeptidase (PEP) and neutral endopeptidase (NEP) to create Ang(1-7)<sup>22</sup>. Even though Ang(1-9) is widely believed to have a vital part in the cardiovascular system, very little is known regarding its biological function<sup>23,24</sup>. In addition, Ang(1-7) can also be created straight from AngI through NEP and prolyl endopeptidase (PREP). Alternatively, AngII can be formed by cleavage of PREP and prolyl carboxypeptidase (PRCP)<sup>25</sup>. Pharmacokinetic experiments have established that the half-life of Ang(1-7) in humans

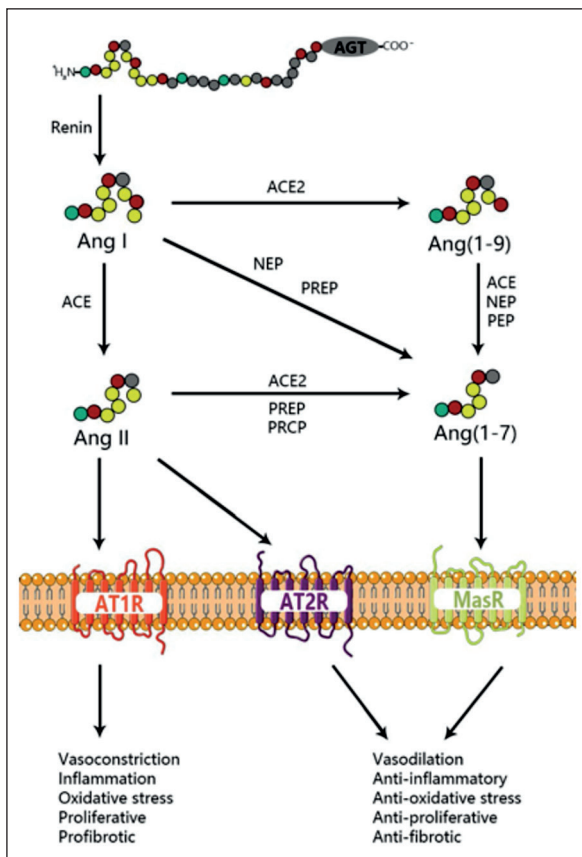

**Figure 1.** A schematic depiction of the renin-angiotensin system's major components. Renin catalyzes the conversion of AGT to AngI. ACE degrades AngI to produce AngII, which exerts its effects on cells by activating two of its major receptors, AT1R and AT2R, with AT1R activity operating in opposition to AT2R activation. ACE2 degrades AngII to produce Ang(1-7), which activates MasR and inhibits the effects of AngII. PREP or PRCP may also degrade AngII directly to produce Ang(1-7). On the other hand, it can be generated directly by cleavage of AngI by NEP or PREP. Additionally, Ang(1-7) can be generated from AngI by ACE2, which requires the formation of the intermediate form Ang(1-9) and subsequent cleavage by ACE, NEP, or PEP.

is very brief, typically only 0.5 hours, while in rats the half-life is even shorter at 9 seconds<sup>26,27</sup>. When it binds with its specific receptor, MasR, Ang(1-7) triggers a cascade of downstream events that negatively regulate the RAS, resulting in vasodilatory, anti-inflammatory, anti-proliferative, anti-oxidative stress and anti-fibrotic effects. This helps to maintain vascular integrity and promote vascular health<sup>28</sup>. It also has the ability to accelerate hematopoiesis and cell differentiation, treat brain diseases and degenerative disorders, treat eye diseases, improve glucose and lipid metabolism, and anti-tumor therapy<sup>29</sup>.

### Mas Receptor

In 1986, Young et al<sup>30</sup> identified a new human oncogene named *Mas*. *Mas* oncogene encodes a 325 amino acid protein, the Mas receptor, initially thought to be an AngII receptor<sup>31</sup>. It was not until 2003 that experiments by Santos et al<sup>32</sup> confirmed that Mas receptors are endogenous and specific for Ang(1-7)<sup>32</sup>. Since then, our knowledge of MasR has only gradually increased.

*Mas* receptors are expressed in a diverse array of cell types, including endothelial cells, cardiomyocytes, and fibroblasts<sup>33-35</sup>. *Mas* expression levels are constantly controlled in the heart by physiological and pathological events<sup>36</sup>. *Mas*-knockout animals exhibit cardiovascular-related phenotypes, including cardiac fibrosis and dysfunction, oxidative stress and endothelial dysfunction, renal dysfunction, diabetes and dyslipidemia<sup>37</sup>.

### The function of the ACE2/Ang(1-7)/MasR Axis in MIRI

#### Controlling Vascular Tone

*ACE2*-deficient mice show impaired endothelium-dependent diastolic function. Overexpression of *ACE2* in turn reversed this impairment. The use of the Ang(1-7) agonist A779 again reduced endothelial diastolic function<sup>38</sup>. It is believed that Ang(1-7) stimulates the MasR, which then activates endothelial nitric oxide synthase (eNOS) through the phosphatidylinositol 3-kinases (PI3K)/ protein kinase B (Akt or PKB) pathway, causing nitric oxide (NO) to be released (Figure 2). The release of NO main cause diastole and vasodilation in the smooth muscle of the vascular wall. At the same time, activation of MasR limits the activity of AngII by blocking intracellular pathways generated by AT1R stimulation, for instance c-Src and extracellular signal-regulated kinase 1/2 (ERK1/2)<sup>39</sup>. Notably, Ang(1-7) may also cause vasodilation through the AT2R, which is involved in the bradykinin- NO pathway<sup>40</sup>. Additionally, Ang(1-7) increases the generation of vasodilators such as prostacyclin (PGI2) and prostaglandins (PGE2) by increasing the activity of phospholipase A2 (PLA2) and arachidonic acid (AA) release<sup>14</sup>. The *ACE2* activator diminazene aceturate (DIZE) or exogenous Ang(1-7) may protect rats against ischemia damage caused by endothelin-1 (ET-1)<sup>41</sup>. Whereas ET-1 is one of the most powerful endogenous vasoconstrictors yet discovered, its elevation has a significant effect on the severity or progression

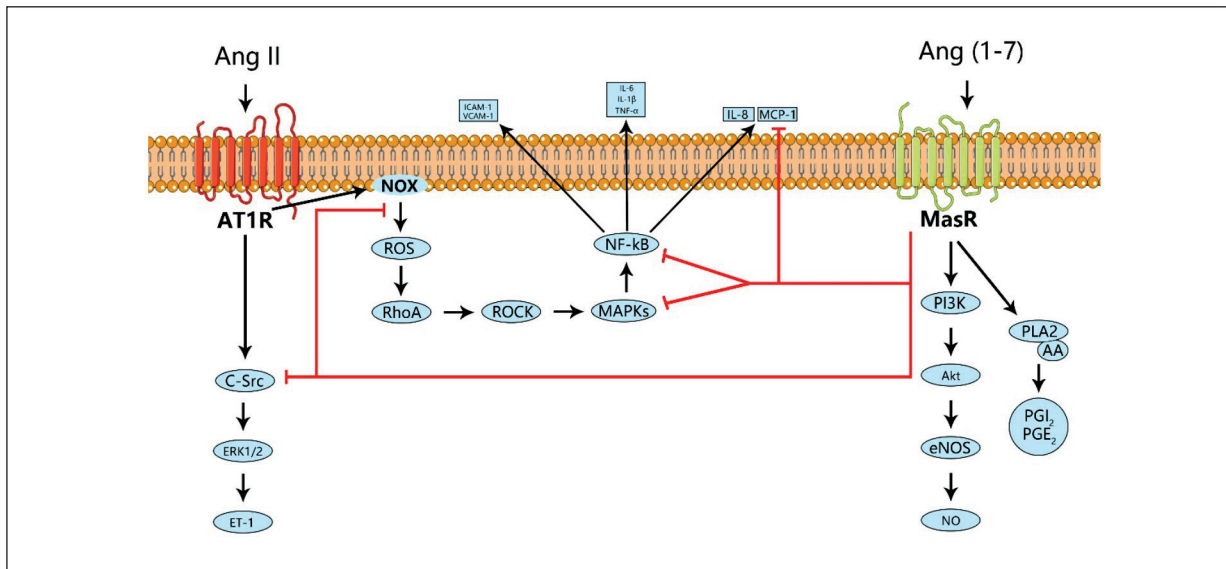

**Figure 2.** The function of the ACE2/Ang(1-7)/MasR axis in MIRI. AngII binds to the AT1R, activates ERK1/2 and c-Src, and promotes the release of ET-1. Moreover, it activates NOX, increases ROS production, and phosphorylates NF-κB, resulting in an increase in the expression of chemokines (MCP-1, IL-8), cytokines (IL-6, IL-1β, TNF-α), and adhesion molecules (ICAM-1, VCAM-1). Ang(1-7) binds to MasR and activates eNOS through the PI3K/Akt pathway to produce NO. Additionally, Ang(1-7) induces the synthesis of vasodilators such as PGI<sub>2</sub> and PGE<sub>2</sub>, by enhancing PLA2 activity and AA release. Furthermore, it inhibits ERK1/2, c-Src, NOX, NF-κB, and MCP-1, which are all downstream targets of AngII.

of MIRI<sup>42</sup>. ET-1 upregulation in MIRI was related with an upregulation of p-ERK1/2<sup>43</sup>. So Ang(1-7) also antagonizes the increase in ET-1 by inhibiting ERK1/2. In short, ACE2 degrades AngII to produce Ang(1-7), reducing vasoconstrictor substances and increasing vasodilator substances. In turn, Ang(1-7) acts by inhibiting AngII and ET-1, causing even more vasodilation.

### Anti-Oxidative Stress

By antagonizing the AngII/AT1R axis and thereby reducing ROS production, the ACE2/Ang(1-7)/MasR axis can reduce oxidative stress damage. The absence of *ACE2* leads to an increase in the production of ROS, which could be mitigated by the addition of recombinant human ACE2(rhACE2)<sup>44</sup>. Inhibition of endogenous Ang(1-7) or MasR results in increased levels of nicotinamide adenine dinucleotide phosphate oxidase (NOX) in the heart<sup>45</sup>. AVE 0991, the Ang(1-7) analogue, can reduce NOX2 and NOX4 in rats<sup>46</sup>. The ACE2/Ang(1-7)/MasR axis also adjusts antioxidant enzymes to reduce oxidative stress damage. The use of rhACE2 increases the expression of superoxide dismutase-2 (SOD2) in mice<sup>47</sup>. Similarly, Ang(1-7) can increase SOD2 expression in rats, thereby reducing ROS levels<sup>48</sup>. In conclusion, the ACE2/Ang(1-7)/MasR axis has

the ability to reduce oxidative injury in the vascular system by increasing antioxidant capacity and decreasing NOX-mediated ROS generation, therefore improving endothelial function.

### Anti-Inflammatory

AngII/AT1R promotes nuclear factor κB (NF-κB) phosphorylation, then activates the pathway. It results in increased production of chemokines [monocyte chemoattractant protein-1 (MCP-1), interleukin-8 (IL-8)], cytokines [interleukin-6 (IL-6), interleukin-1β (IL-1β), tumor necrosis factor α (TNF-α)] and adhesion molecules [intercellular cell adhesion molecule-1(ICAM-1), vascular cell adhesion molecule-1 (VCAM-1)]<sup>49</sup>. In *ApoE*-knockout mice, genetic defects in *ACE2* cause increased production of adhesion molecules, chemokines and cytokines, which further exacerbate their vascular inflammation<sup>50</sup>. *ACE2* overexpression decreased the production of MCP-1 in macrophages stimulated by AngII. This influence appears to be mediated by a rise in Ang(1-7) levels<sup>51</sup>. Another study<sup>50</sup> found that Ang(1-7) was effective in decreasing inflammation in rats by inhibiting the production of pro-inflammatory factors. Additionally, it has been shown that Ang(1-7) inhibits leukocyte rolling and adherence to the microvascular endothelium<sup>52</sup>. Ang(1-



7) suppresses the inflammatory effects of AngII by blocking the NOX and pro-inflammatory signaling pathways in human aortic smooth muscle cells<sup>53</sup>. For the most part, these findings suggest that the ACE2/Ang(1-7)/MasR axis has a role in reducing vascular inflammation.

### **Other Roles**

Autophagy of cardiomyocytes after ischemia reperfusion injury has a damaging effect on the myocardium<sup>54</sup>. Mammalian target of rapamycin (mTOR), a critical negative regulator of autophagy, can be activated by Akt<sup>55</sup>. In hypoxia re-oxygenated cardiomyocytes, upregulation of Ang(1-7) can inhibit autophagy by activating Akt<sup>56</sup>. Akt activation not only controls autophagy following MIRI, but it also protects the heart against MIRI by increasing mitochondrial elongation and preventing the opening of the mitochondrial protein transporter (mPTP)<sup>57</sup>. Additionally, Ang(1-7) inhibits AngII-induced apoptosis by modulating eNOS phosphorylation<sup>58</sup>. Furthermore, Ang(1-7) can protect cardiomyocytes from MIRI by restoring intracellular calcium homeostasis<sup>59</sup>. Ang(1-7) produces an anti-ischemia-reperfusion injury effect, which is concentration dependent, with a protective effect at 0.22 nmol/L and a reduction in coronary flow at 27 nmol/L. Ang(1-7) seems to have a bidirectional effect on the body, and larger amounts are not always better for one's well-being<sup>60</sup>.

### **The Therapeutic Approaches and Potential of Enhancing the ACE2/Ang(1-7)/MasR Axis in MIRI**

ACEI and angiotensin receptor blocker (ARB) have shown clinical efficacy in the treatment of a variety of cardiovascular disorders, indicating that chemical modulators targeting other bioactive constituents of the RAS might be developed. The ACE2/Ang(1-7)/MasR axis has been an endogenous counter-regulatory system inside the RAS, which provides a possibility to prevent and cure MIRI through endogenous mechanisms. Plasma concentrations of AngII were considerably reduced in individuals treated with rhACE2, although those of Ang(1-7) were raised, and they all had improved cardiac function<sup>61</sup>. In addition, healthy people tolerated individual and repeated doses of rhACE2 nicely, with no severe adverse effects or dosages toxicity seen following treatment<sup>62</sup>. ACE2 activator, such as 1-[(2-dimethylamino) ethylamino]-4-(hydroxymethyl)-7-[(4-methylphenyl)

sulfonyloxy]-9Hxanthene-9-one (XNT), can ameliorate diabetes-induced heart dysfunction in rats<sup>63</sup>. It also has the additional effect of lowering blood pressure in spontaneously hypertensive rats, improving cardiac function<sup>64</sup>. DIZE therapy significantly decreased the extent of myocardial infarctions in rats, reduced inflammatory cells of the peri-infarct cardiac area, delayed post-infarct left ventricular remodeling, and restored normal cardiac RAS balance<sup>65</sup>. In rats with myocardial infarction, the non-peptide Ang(1-7) analog AVE-0991 also enhances cardiac function and reduces ventricular remodeling<sup>66</sup>. Natural Ang(1-7) is unstable in the gastrointestinal system, and hence a formulation of hydroxypropyl  $\beta$ -cyclodextrin-bound Ang(1-7) [HP $\beta$ CD/Ang(1-7)] was developed to alleviate this instability. In rats suffering from myocardial infarction as a result of coronary artery blockage, oral treatment of HP $\beta$ CD/Ang(1-7) had considerable cardioprotective benefits<sup>67</sup>.

### **Conclusions**

ACE2, a prominent member of the RAS, performs a crucial regulatory function in the cardiovascular system. ACE2 regulates the RAS inversely mainly by hydrolyzing the harmful AngII to the beneficial Ang(1-7). Clinical as well as experimental studies have conclusively demonstrated that the ACE2/Ang(1-7)/MasR axis is important in both physiological and pathological processes in MIRI, and studies have suggested that increasing or activating ACE2 or Ang(1-7) may help prevent and treat MIRI. This opens the door to new concepts and therapy targets for MIRI prevention and treatment. However, additional research into the specific processes behind the ACE2/Ang(1-7)/MasR axis in MIRI is necessary, as is the performance of additional in-depth studies to go from basic research to clinical translation.

### **Conflict of Interest**

The Authors declare that they have no conflict of interests.

### **Acknowledgements**

This work was supported by Scientific Research Foundation of Hunan Provincial Education Department of China [No. 19A432].

## References

- 1) Kaski JC, Crea F, Gersh BJ, Camici PG. Reappraisal of Ischemic Heart Disease. *Circulation* 2018; 138: 1463-1480.
- 2) Patel MR, Calhoun JH, Dehmer GJ, Grantham JA, Maddox TM, Maron DJ, Smith PK. ACC/AATS/AHA/ASE/ASNC/SCAI/SCCT/STS 2017 Appropriate Use Criteria for Coronary Revascularization in Patients With Stable Ischemic Heart Disease: A Report of the American College of Cardiology Appropriate Use Criteria Task Force, American Association for Thoracic Surgery, American Heart Association, American Society of Echocardiography, American Society of Nuclear Cardiology, Society for Cardiovascular Angiography and Interventions, Society of Cardiovascular Computed Tomography, and Society of Thoracic Surgeons. *J Am Coll Cardiol* 2017; 69: 2212-2241.
- 3) Bi X, Zhang G, Wang X, Nguyen C, May HI, Li X, Al-Hashimi AA, Austin RC, Gillette TG, Fu G, Wang ZV, Hill JA. Endoplasmic Reticulum Chaperone GRP78 Protects Heart From Ischemia/Reperfusion Injury Through Akt Activation. *Circ Res* 2018; 122: 1545-1554.
- 4) Yellon DM, Hausenloy DJ. Myocardial reperfusion injury. *N Engl J Med* 2007; 357: 1121-1135.
- 5) Wang G, Zhang Q, Yuan W, Wu J, Li C. Sildenafil Protects against Myocardial Ischemia-Reperfusion Injury Following Cardiac Arrest in a Porcine Model: Possible Role of the Renin-Angiotensin System. *Int J Mol Sci* 2015; 16: 27015-27031.
- 6) Verma K, Pant M, Paliwal S, Dwivedi J, Sharma S. An Insight on Multicentric Signaling of Angiotensin II in Cardiovascular system: A Recent Update. *Front Pharmacol* 2021; 12: 734917.
- 7) Paz Ocaranza M, Riquelme JA, García L, Jalil JE, Chiong M, Santos RAS, Lavandero S. Counter-regulatory renin-angiotensin system in cardiovascular disease. *Nat Rev Cardiol* 2020; 17: 116-129.
- 8) Nehme A, Zouein FA, Zayeri ZD, Zibara K. An Update on the Tissue Renin Angiotensin System and Its Role in Physiology and Pathology. *J Cardiovasc Dev Dis* 2019; 6.
- 9) Hooper NM, Lambert DW, Turner AJ. Discovery and characterization of ACE2 - a 20-year journey of surprises from vasopeptidase to COVID-19. *Clin Sci (Lond)* 2020; 134: 2489-2501.
- 10) Donoghue M, Hsieh F, Baronas E, Godbout K, Gosselin M, Stagliano N, Donovan M, Woolf B, Robison K, Jeyaseelan R, Breitbart RE, Acton S. A novel angiotensin-converting enzyme-related carboxypeptidase (ACE2) converts angiotensin I to angiotensin 1-9. *Circ Res* 2000; 87: E1-E9.
- 11) García-Escobar A, Jiménez-Valero S, Galeote G, Jurado-Román A, García-Rodríguez J, Moreno R. The soluble catalytic ectodomain of ACE2 a biomarker of cardiac remodelling: new insights for heart failure and COVID19. *Heart Fail Rev* 2021; 26: 961-971.
- 12) Turner AJ, Tipnis SR, Guy JL, Rice G, Hooper NM. ACEH/ACE2 is a novel mammalian metallo-carboxypeptidase and a homologue of angiotensin-converting enzyme insensitive to ACE inhibitors. *Can J Physiol Pharmacol* 2002; 80: 346-353.
- 13) Tipnis SR, Hooper NM, Hyde R, Karran E, Christie G, Turner AJ. A human homolog of angiotensin-converting enzyme. Cloning and functional expression as a captopril-insensitive carboxypeptidase. *J Biol Chem* 2000; 275: 33238-33243.
- 14) Amraei R, Rahimi N. COVID-19, Renin-Angiotensin System and Endothelial Dysfunction. *Cells* 2020; 9.
- 15) Pillay TS. Gene of the month: the 2019-nCoV/SARS-CoV-2 novel coronavirus spike protein. *J Clin Pathol* 2020; 73: 366-369.
- 16) Patel VB, Zhong JC, Fan D, Basu R, Morton JS, Parajuli N, McMurtry MS, Davidge ST, Kassiri Z, Oudit GY. Angiotensin-converting enzyme 2 is a critical determinant of angiotensin II-induced loss of vascular smooth muscle cells and adverse vascular remodeling. *Hypertension* 2014; 64: 157-164.
- 17) Wiese O, Zemlin AE, Pillay TS. Molecules in pathogenesis: angiotensin converting enzyme 2 (ACE2). *J Clin Pathol* 2021; 74: 285-290.
- 18) Gheblawi M, Wang K, Viveiros A, Nguyen Q, Zhong JC, Turner AJ, Raizada MK, Grant MB, Oudit GY. Angiotensin-Converting Enzyme 2: SARS-CoV-2 Receptor and Regulator of the Renin-Angiotensin System: Celebrating the 20th Anniversary of the Discovery of ACE2. *Circ Res* 2020; 126: 1456-1474.
- 19) Simko F, Hrenak J, Adamcova M, Paulis L. Renin-Angiotensin-Aldosterone System: Friend or Foe-The Matter of Balance. Insight on History, Therapeutic Implications and COVID-19 Interactions. *Int J Mol Sci* 2021; 22.
- 20) Yamamoto K, Takeshita H, Rakugi H. ACE2, angiotensin 1-7 and skeletal muscle: review in the era of COVID-19. *Clin Sci (Lond)* 2020; 134: 3047-3062.
- 21) Li S, Ma W, Yang F, Xu Y, Xu B, Cai B. ACE2 as a Key Target for Treatment of COVID-19 Related Cardiovascular Diseases: Current Progress and Prospect. *Curr Drug Targets* 2021; 22: 1832-1843.
- 22) Verano-Braga T, Martins ALV, Motta-Santos D, Campagnole-Santos MJ, Santos RAS. ACE2 in the renin-angiotensin system. *Clin Sci (Lond)* 2020; 134: 3063-3078.
- 23) Flores-Muñoz M, Godinho BM, Almalik A, Nicklin SA. Adenoviral delivery of angiotensin-(1-7) or angiotensin-(1-9) inhibits cardiomyocyte hypertrophy via the mas or angiotensin type 2 receptor. *PLoS One* 2012; 7: e45564.
- 24) Flores-Munoz M, Work LM, Douglas K, Denby L, Dominiczak AF, Graham D, Nicklin SA. Angiotensin-(1-9) attenuates cardiac fibrosis in the stroke-prone spontaneously hypertensive rat via the angiotensin type 2 receptor. *Hypertension* 2012; 59: 300-307.

- 25) Santos RA, Ferreira AJ, Verano-Braga T, Bader M. Angiotensin-converting enzyme 2, angiotensin-(1-7) and Mas: new players of the renin-angiotensin system. *J Endocrinol* 2013; 216: R1-R17.
- 26) Petty WJ, Miller AA, McCoy TP, Gallagher PE, Tallant EA, Torti FM. Phase I and pharmacokinetic study of angiotensin-(1-7), an endogenous antiangiogenic hormone. *Clin Cancer Res* 2009; 15: 7398-7404.
- 27) Yamada K, Iyer SN, Chappell MC, Ganten D, Ferrario CM. Converting enzyme determines plasma clearance of angiotensin-(1-7). *Hypertension* 1998; 32: 496-502.
- 28) Touyz RM, Montezano AC. Angiotensin-(1-7) and Vascular Function: The Clinical Context. *Hypertension* 2018; 71: 68-69.
- 29) Machado-Silva A, Passos-Silva D, Santos RA, Sinisterra RD. Therapeutic uses for Angiotensin-(1-7). *Expert Opin Ther Pat* 2016; 26: 669-678.
- 30) Young D, Waitches G, Birchmeier C, Fasano O, Wigler M. Isolation and characterization of a new cellular oncogene encoding a protein with multiple potential transmembrane domains. *Cell* 1986; 45: 711-719.
- 31) Jackson TR, Blair LA, Marshall J, Goedert M, Hanley MR. The mas oncogene encodes an angiotensin receptor. *Nature* 1988; 335: 437-440.
- 32) Santos RA, Simoes e Silva AC, Maric C, Silva DM, Machado RP, de Buhr I, Heringer-Walther S, Pinheiro SV, Lopes MT, Bader M, Mendes EP, Lemos VS, Campagnole-Santos MJ, Schultheiss HP, Speth R, Walther T. Angiotensin-(1-7) is an endogenous ligand for the G protein-coupled receptor Mas. *Proc Natl Acad Sci U S A* 2003; 100: 8258-8263.
- 33) Sampaio WO, Souza dos Santos RA, Faria-Silva R, da Mata Machado LT, Schiffrin EL, Touyz RM. Angiotensin-(1-7) through receptor Mas mediates endothelial nitric oxide synthase activation via Akt-dependent pathways. *Hypertension* 2007; 49: 185-192.
- 34) Santos RA, Castro CH, Gava E, Pinheiro SV, Almeida AP, Paula RD, Cruz JS, Ramos AS, Rosa KT, Irigoyen MC, Bader M, Alenina N, Kitten GT, Ferreira AJ. Impairment of in vitro and in vivo heart function in angiotensin-(1-7) receptor MAS knockout mice. *Hypertension* 2006; 47: 996-1002.
- 35) Iwata M, Cowling RT, Gurantz D, Moore C, Zhang S, Yuan JX, Greenberg BH. Angiotensin-(1-7) binds to specific receptors on cardiac fibroblasts to initiate antifibrotic and antitrophic effects. *Am J Physiol Heart Circ Physiol* 2005; 289: H2356-H2363.
- 36) Dias-Peixoto MF, Ferreira AJ, Almeida PW, Braga VB, Coutinho DC, Melo DS, Gomes Filho A, Melo MB, Greco L, Campagnole-Santos MJ, Lima RF, Santos RA, Guatimosim S. The cardiac expression of Mas receptor is responsive to different physiological and pathological stimuli. *Pepptides* 2012; 35: 196-201.
- 37) Santos RAS, Sampaio WO, Alzamora AC, Motta-Santos D, Alenina N, Bader M, Campagnole-Santos MJ. The ACE2/Angiotensin-(1-7)/MAS Axis of the Renin-Angiotensin System: Focus on Angiotensin-(1-7). *Physiol Rev* 2018; 98: 505-553.
- 38) Lovren F, Pan Y, Quan A, Teoh H, Wang G, Shukla PC, Levitt KS, Oudit GY, Al-Omran M, Stewart DJ, Slutsky AS, Peterson MD, Backx PH, Penninger JM, Verma S. Angiotensin converting enzyme-2 confers endothelial protection and attenuates atherosclerosis. *Am J Physiol Heart Circ Physiol* 2008; 295: H1377-H1384.
- 39) van Twist DJ, Kroon AA, de Leeuw PW. Angiotensin-(1-7) as a strategy in the treatment of hypertension? *Curr Opin Nephrol Hypertens* 2014; 23: 480-486.
- 40) Walters PE, Gaspari TA, Widdop RE. Angiotensin-(1-7) acts as a vasodepressor agent via angiotensin II type 2 receptors in conscious rats. *Hypertension* 2005; 45: 960-966.
- 41) Mecca AP, Regenhardt RW, O'Connor TE, Joseph JP, Raizada MK, Katovich MJ, Sumners C. Cerebroprotection by angiotensin-(1-7) in endothelin-1-induced ischaemic stroke. *Exp Physiol* 2011; 96: 1084-1096.
- 42) Tamarelle S, Terwelp M, Amirian J, Felli P, Zhang XQ, Barry WH, Smalling RW. Endothelin-1 release during the early phase of reperfusion is a mediator of myocardial reperfusion injury. *Cardiology* 2013; 125: 242-249.
- 43) Skovsted GF, Kruse LS, Berchtold LA, Grell AS, Warfvinge K, Edvinsson L. Myocardial ischemia-reperfusion enhances transcriptional expression of endothelin-1 and vasoconstrictor ETB receptors via the protein kinase MEK-ERK1/2 signaling pathway in rat. *PLoS One* 2017; 12: e0174119.
- 44) Zhong J, Basu R, Guo D, Chow FL, Byrns S, Schuster M, Loibner H, Wang XH, Penninger JM, Kassiri Z, Oudit GY. Angiotensin-converting enzyme 2 suppresses pathological hypertrophy, myocardial fibrosis, and cardiac dysfunction. *Circulation* 2010; 122: 717-728.
- 45) Yousif MH, Dhaunsi GS, Makki BM, Qabazard BA, Akhtar S, Benter IF. Characterization of Angiotensin-(1-7) effects on the cardiovascular system in an experimental model of type-1 diabetes. *Pharmacol Res* 2012; 66: 269-275.
- 46) Ma Y, Huang H, Jiang J, Wu L, Lin C, Tang A, Dai G, He J, Chen Y. AVE 0991 attenuates cardiac hypertrophy through reducing oxidative stress. *Biochem Biophys Res Commun* 2016; 474: 621-625.
- 47) Rathinasabapathy A, Bryant AJ, Suzuki T, Moore C, Shay S, Gladson S, West JD, Carrier EJ. rhACE2 Therapy Modifies Bleomycin-Induced Pulmonary Hypertension via Rescue of Vascular Remodeling. *Front Physiol* 2018; 9: 271.
- 48) Guo L, Yin A, Zhang Q, Zhong T, O'Rourke ST, Sun C. Angiotensin-(1-7) attenuates angiotensin



- II-induced cardiac hypertrophy via a Sirt3-dependent mechanism. *Am J Physiol Heart Circ Physiol* 2017; 312: H980-H991.
- 49) Cantero-Navarro E, Fernández-Fernández B, Ramos AM, Rayego-Mateos S, Rodrigues-Diez RR, Sánchez-Niño MD, Sanz AB, Ruiz-Ortega M, Ortiz A. Renin-angiotensin system and inflammation update. *Mol Cell Endocrinol* 2021; 529: 111254.
  - 50) Thomas MC, Pickering RJ, Tsorotes D, Koitka A, Sheehy K, Bernardi S, Toffoli B, Nguyen-Huu TP, Head GA, Fu Y, Chin-Dusting J, Cooper ME, Tikellis C. Genetic Ace2 deficiency accentuates vascular inflammation and atherosclerosis in the ApoE knockout mouse. *Circ Res* 2010; 107: 888-897.
  - 51) Guo YJ, Li WH, Wu R, Xie Q, Cui LQ. ACE2 over-expression inhibits angiotensin II-induced monocyte chemoattractant protein-1 expression in macrophages. *Arch Med Res* 2008; 39: 149-154.
  - 52) da Silveira KD, Coelho FM, Vieira AT, Sachs D, Barroso LC, Costa VV, Bretas TL, Bader M, de Sousa LP, da Silva TA, dos Santos RA, Simões e Silva AC, Teixeira MM. Anti-inflammatory effects of the activation of the angiotensin-(1-7) receptor, MAS, in experimental models of arthritis. *J Immunol* 2010; 185: 5569-5576.
  - 53) Villalobos LA, San Hipólito-Luengo Á, Ramos-González M, Cercas E, Vallejo S, Romero A, Romacho T, Carraro R, Sánchez-Ferrer CF, Peiró C. The Angiotensin-(1-7)/Mas Axis Counteracts Angiotensin II-Dependent and -Independent Pro-inflammatory Signaling in Human Vascular Smooth Muscle Cells. *Front Pharmacol* 2016; 7: 482.
  - 54) Yao L, Chen H, Wu Q, Xie K. Hydrogen-rich saline alleviates inflammation and apoptosis in myocardial I/R injury via PINK-mediated autophagy. *Int J Mol Med* 2019; 44: 1048-1062.
  - 55) Liang P, Jiang B, Li Y, Liu Z, Zhang P, Zhang M, Huang X, Xiao X. Autophagy promotes angiogenesis via AMPK/Akt/mTOR signaling during the recovery of heat-denatured endothelial cells. *Cell Death Dis* 2018; 9: 1152.
  - 56) Hao P, Liu Y, Guo H, Zhang Z, Chen Q, Hao G, Zhang C, Zhang Y. Prolylcarboxypeptidase Mitigates Myocardial Ischemia/Reperfusion Injury by Stabilizing Mitophagy. *Front Cell Dev Biol* 2020; 8: 584933.
  - 57) Ong SB, Hall AR, Dongworth RK, Kalkhoran S, Pyakurel A, Scorrano L, Hausenloy DJ. Akt protects the heart against ischaemia-reperfusion injury by modulating mitochondrial morphology. *Thromb Haemost* 2015; 113: 513-521.
  - 58) Zhang L, Wang J, Liang J, Feng D, Deng F, Yang Y, Lu Y, Hu Z. Propofol prevents human umbilical vein endothelial cell injury from Ang II-induced apoptosis by activating the ACE2-(1-7)-Mas axis and eNOS phosphorylation. *PLoS One* 2018; 13: e0199373.
  - 59) Wang L, Luo D, Liao X, He J, Liu C, Yang C, Ma H. Ang-(1-7) offers cytoprotection against ischemia-reperfusion injury by restoring intracellular calcium homeostasis. *J Cardiovasc Pharmacol* 2014; 63: 259-264.
  - 60) Ferreira AJ, Santos RA, Almeida AP. Angiotensin-(1-7): cardioprotective effect in myocardial ischemia/reperfusion. *Hypertension* 2001; 38: 665-668.
  - 61) Haschke M, Schuster M, Poglitsch M, Loibner H, Salzberg M, Bruggisser M, Penninger J, Krähenbühl S. Pharmacokinetics and pharmacodynamics of recombinant human angiotensin-converting enzyme 2 in healthy human subjects. *Clin Pharmacokinet* 2013; 52: 783-792.
  - 62) Basu R, Poglitsch M, Yogasundaram H, Thomas J, Rowe BH, Oudit GY. Roles of Angiotensin Peptides and Recombinant Human ACE2 in Heart Failure. *J Am Coll Cardiol* 2017; 69: 805-819.
  - 63) Murça TM, Moraes PL, Capuruço CA, Santos SH, Melo MB, Santos RA, Shenoy V, Katovich MJ, Raizada MK, Ferreira AJ. Oral administration of an angiotensin-converting enzyme 2 activator ameliorates diabetes-induced cardiac dysfunction. *Regul Pept* 2012; 177: 107-115.
  - 64) Hernández Prada JA, Ferreira AJ, Katovich MJ, Shenoy V, Qi Y, Santos RA, Castellano RK, Lampkins AJ, Gubala V, Ostrov DA, Raizada MK. Structure-based identification of small-molecule angiotensin-converting enzyme 2 activators as novel antihypertensive agents. *Hypertension* 2008; 51: 1312-1317.
  - 65) Qi Y, Zhang J, Cole-Jeffrey CT, Shenoy V, Espejo A, Hanna M, Song C, Pepine CJ, Katovich MJ, Raizada MK. Diminazene aceturate enhances angiotensin-converting enzyme 2 activity and attenuates ischemia-induced cardiac pathophysiology. *Hypertension* 2013; 62: 746-752.
  - 66) Zeng WT, Chen WY, Leng XY, Tang LL, Sun XT, Li CL, Dai G. Impairment of cardiac function and remodeling induced by myocardial infarction in rats are attenuated by the nonpeptide angiotensin-(1-7) analog AVE 0991. *Cardiovasc Ther* 2012; 30: 152-161.
  - 67) Marques FD, Ferreira AJ, Sinisterra RD, Jacoby BA, Sousa FB, Caliarí MV, Silva GA, Melo MB, Nadu AP, Souza LE, Irigoyen MC, Almeida AP, Santos RA. An oral formulation of angiotensin-(1-7) produces cardioprotective effects in infarcted and isoproterenol-treated rats. *Hypertension* 2011; 57: 477-483.